



Brick Snap[®] Planning & Installation Guide

Scott System, Inc.

10777 East 45th Ave. Denver, CO 80239
Phone: (303) 373-2500 Fax: (303) 373-2755
www.scottsystem.com

Contents

Planning & Design (p.3-5)

- A. Modules
- B. Coursing Options
- C. Returns & Corners
- D. Details & Options with Brick Snaps®

Estimating (p.6-9)

- A. Brick Take-offs
- B. Cost
- C. Brick Snap® Specifications & Details

Installation (p.10-13)

- A. Storage
- B. Assembly in the Form
- C. Cutting the Brick and the Snap®
- D. Corner Application
- E. Pouring the Concrete
- F. Finishing the Panel: Stripping the Snaps®
- G. Finishing the Panel: Cleaning the Panel

General (p.13)

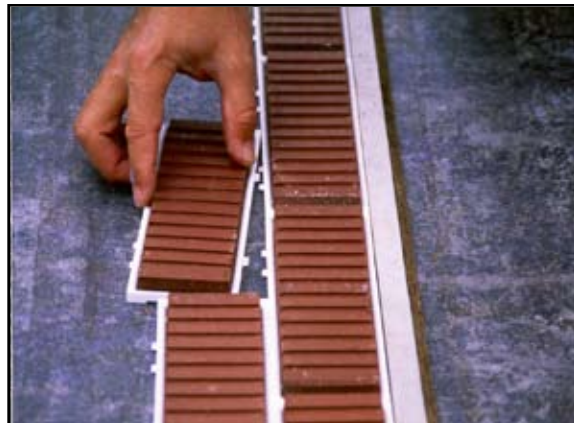

The Brick Snap® method is a simple and economical way to achieve a real brick facade in precast or site-cast concrete applications.

Since the introduction of the Brick Snap® in 1995, the tilt-up industry has undergone major expansion, enabling contractors, architects and engineers to save time and money on projects.





Planning & Design

The first rule in planning and design is to develop a mock-up panel representative of your project. The mock-up should incorporate all the conditions of the actual job to help you anticipate what the final project will look like.

A. Modules

Brick Snap® are available in several brick sizes, including Standard, Standard Halves, Modular, Block and Utility. Standard, Halves and Modular each lay out in an 8" module (within +/- 1/64" Snap® tolerance) as shown. In order to make the Brick Snap® easier to install, we suggest keeping panel dimensions and openings for windows and doors in accordance with these modules.

See pages 7-9 for Brick Snap® dimensional layouts for the Standard and Utility size Brick Snap®. These drawings show a half mortar joint at the panel edge, no mortar joint at the panel edge and a corner brick at the panel edge.

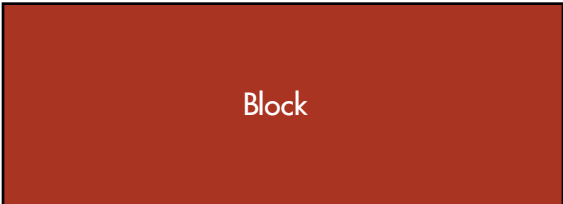
	Actual Brick dimensions (+0/- 1/16")
 Standard	$2\frac{1}{4}" \times 7\frac{5}{8}"$
 Modular	$3\frac{5}{8}" \times 7\frac{5}{8}"$
 Utility	$3\frac{5}{8}" \times 11\frac{5}{8}"$
 4 x 4	$3\frac{5}{8}" \times 3\frac{5}{8}"$
 Standard Half	$2\frac{1}{4}" \times 3\frac{5}{8}"$
 Block	$7\frac{5}{8}" \times 15\frac{5}{8}"$

Note: Dimensions are +/- 1/64"

B. Coursing Options

Presently, Brick Snap® in all sizes assemble to produce a running bond, soldier coursing and a stacked bond, or a combination of these common brick patterns. By using the standard and standard halves, a Flemish bond can be achieved.

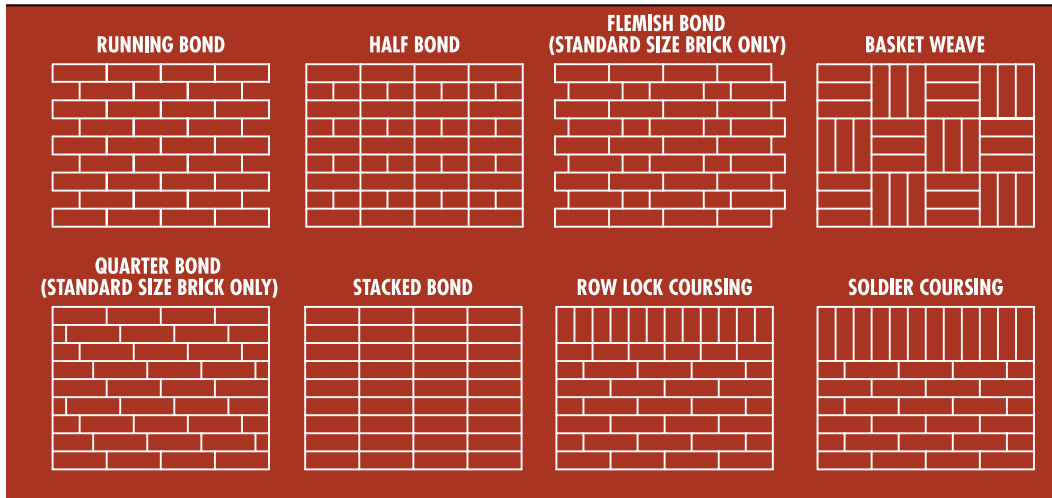

A Multitude of Design Details Can Be Achieved Using Brick Snaps®:

Architectural plans should include panel drawings with brick coursing correctly dimensioned.

C. Returns and Corners

For window wraps and returns, 90° corners and edge caps are available. Most designs incorporate corner brick, so it is best to determine layout early in the drawing phase. When a corner (return) is utilized, the brick layout width will be reduced by 1/8" because the 3/16" half mortar joint is replaced by the 1/16" snap backing thickness.

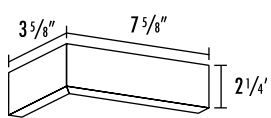

Corner Pieces per lineal foot

4.5 pieces

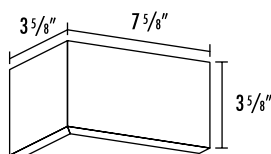

3 pieces

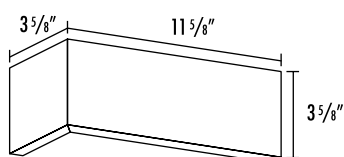

3 pieces

Mortar Joint Dimensions:

Vertical joint: 1/4" deep x .375" wide
 Horizontal joint: 1/4" deep x .4166" high

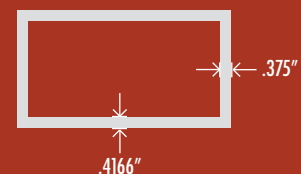

D. Details and Options with Brick Snaps®

Brick Snap® carriers form a tooled joint, creating a field-laid masonry appearance. This covered detail is typically preferred aesthetically and functionally because of its natural water-shedding ability.

Corner installations are simplified with the Add-A-Corner connector shown below. Just slip the Add-A-Corner Snap® piece on the short end of the corner brick and slip a standard size Snap® (cut to size) to the long leg to form a perfectly tooled mortar joint.

Brick Snap® also accommodates brick cut in half (at the beginning of a course for instance) or bricks cut to any length by adding an end cap to the cut end. The half Snaps® and the end caps are designed to make placement easier and faster.

The following drawings illustrate the many sizes and variations possible with the Brick Snap®.

Brick Snap Options

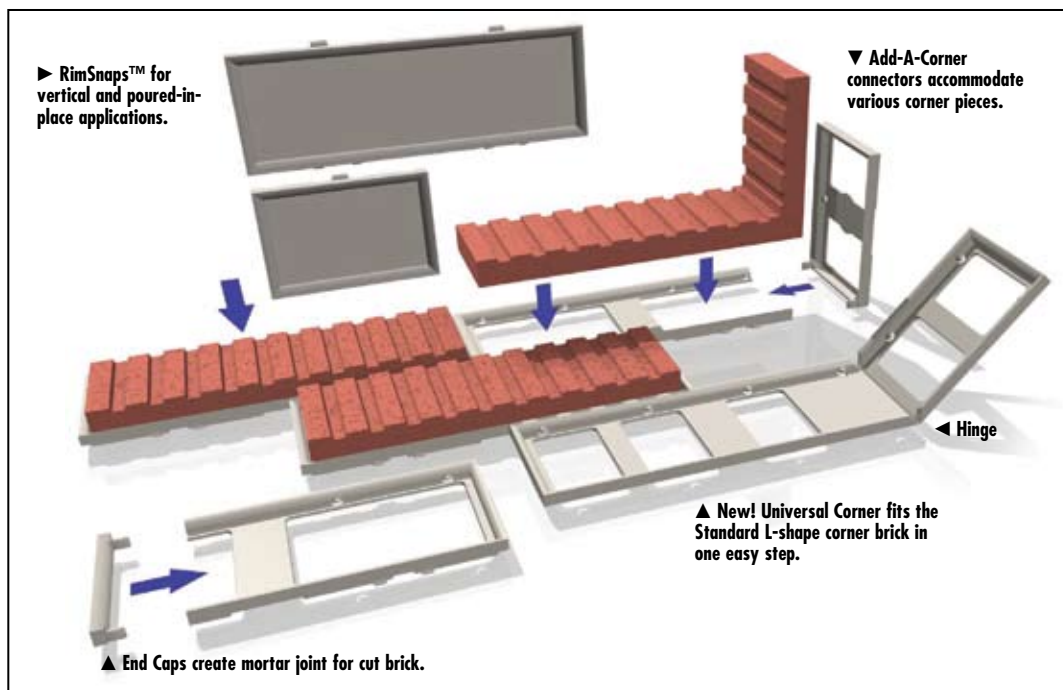

Estimating

A. Brick Take-off

Estimate the total square footage of brick on your project. Remember to exclude window and door openings and other areas that will not require brick. Use the brick sizes and pieces per square foot in the chart below to determine your Brick Snap® quantity. We recommend a 5 to 7 percent allowance on flats and 10 to 15 percent allowance for corners and edge caps for breakage and cuts on most jobs. We will also develop a non-guaranteed take-off to confirm your numbers.

B. Cost

Based on our experience with various projects around the country, Scott System can provide a time estimate on the installation of the Brick Snap®, as well as pricing for the Brick Snap® product and delivery. Because costs fluctuate based on raw material, labor rates and market condition, please call us for current pricing and installation figures.

Estimating Brick Quantity:

Use the chart below to determine the brick quantity necessary for your project. For corners and returns, use a lineal foot calculation.

	Brick dimensions	Pieces per square foot	Module
Standard	2¼" x 7⅝"	6.75 pieces	8 inches = 3 brick tall with 3 mortar joints 8 inches = 1 brick wide with 1 mortar joint
Modular	3⅝" x 7⅝"	4.5 pieces	8 inches = 2 brick tall with 2 mortar joints 8 inches = 1 brick wide with 1 mortar joint
Utility	3⅝" x 11⅝"	3 pieces	12 inches = 3 brick tall with 3 mortar joints 12 inches = 1 brick wide with 1 mortar joint
4 x 4	3⅝" x 3⅝"	9 pieces	
Standard Half	2¼" x 3⅝"	13.5 pieces	
Block	7⅝" x 15⅝"	1.3 pieces	

Please note that brick used in the Brick Snap® meets or exceeds the ASTM specifications. Due to natural characteristics of the raw materials used in the production process of thin brick, brick may vary in size and shade from carton to carton and shipment to shipment. During the installation process, workers should select brick from multiple pallets and cartons to achieve a random blend. Additionally, brick should be ordered in quantities sufficient to complete the installation so that all the brick can be produced at the same time for the same run. Brick supplied for a particular installation may vary in color tone and texture from samples.

BRICK SNAP DIMENSIONAL LAYOUT

(NO MORTAR JOINT AT THE PANEL EDGE)

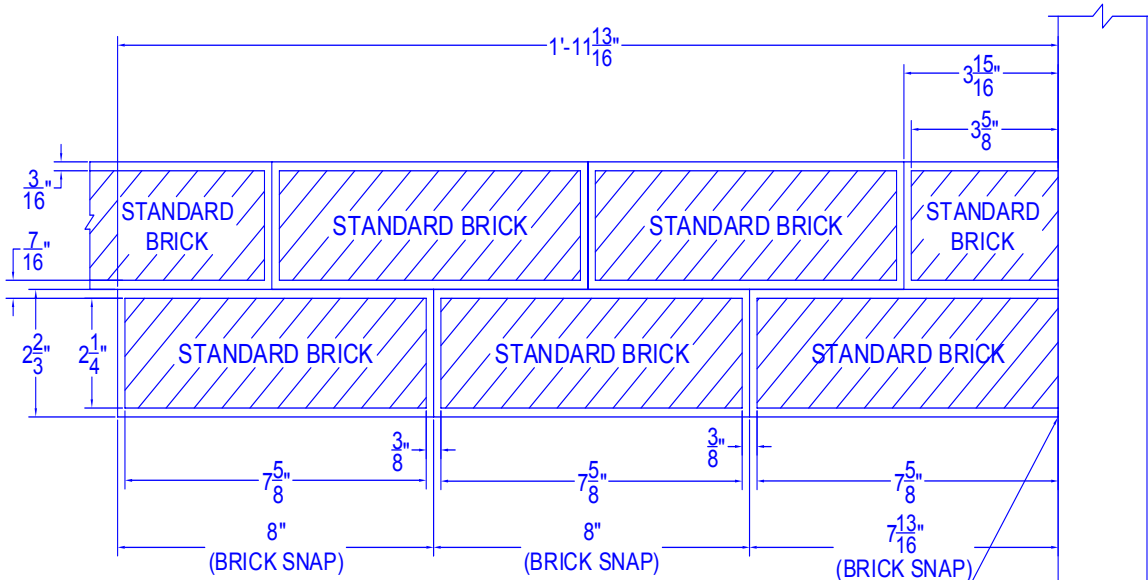

Note: Brick Snap tolerance is +/- 1/64"

Scott System, Inc. (303) 373-2500
COPYRIGHT 2000

NO MORTAR JOINT
AT THE EDGE OF THE
PANEL

EDGE OF THE PANEL
(BULK HEAD)

BRICK SNAP DIMENSIONAL LAYOUT

(1/2 MORTAR JOINT AT THE PANEL EDGE)

3 BRICKS, CENTER OF MORTAR JOINT TO CENTER OF MORTAR JOINT = 3'-0" (36") HORIZONTAL

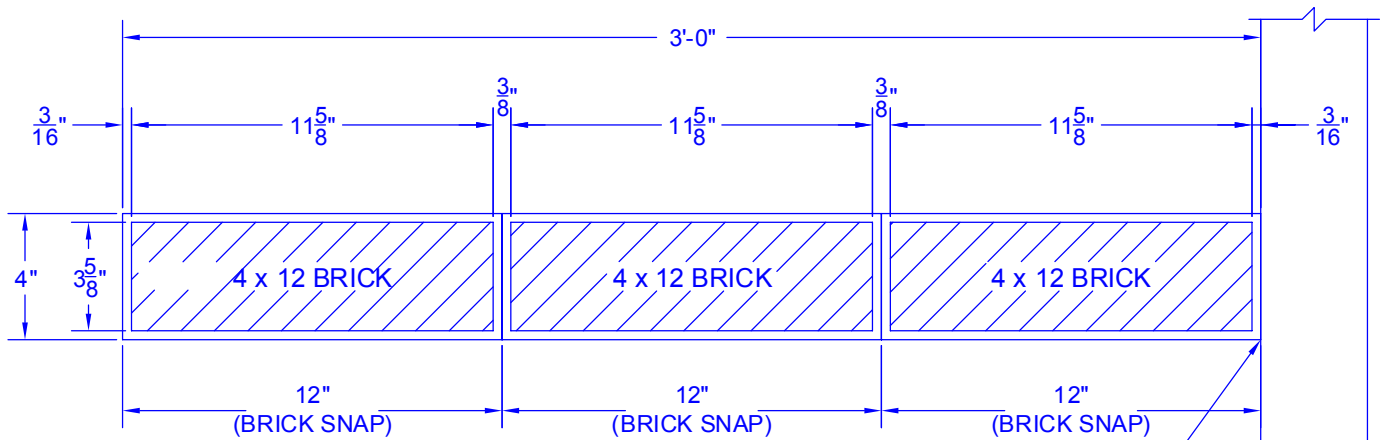

Note: Brick Snap tolerance is +/- 1/64"

Scott System, Inc. (303) 373-2500
COPYRIGHT 2000

1/2 OF A MORTAR
JOINT AT THE EDGE
OF THE PANEL

EDGE OF THE PANEL
(BULK HEAD)

STANDARD BRICK $2\frac{1}{4}" \times 7\frac{5}{8}"$ BRICK SNAP DIMENSIONAL LAYOUT

(ADD-A-CORNER AT THE PANEL EDGE)

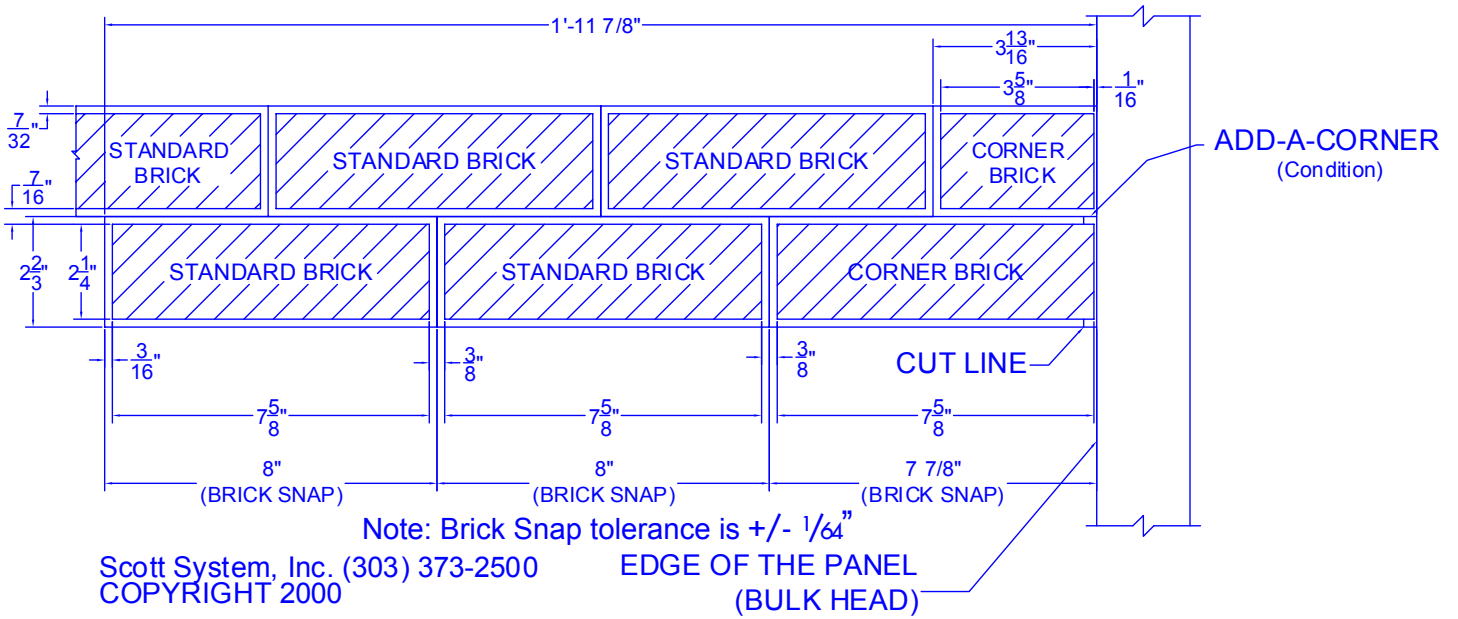

BRICK SNAP DIMENSIONAL LAYOUT

(ADD-A-CORNER AT THE PANEL EDGE)

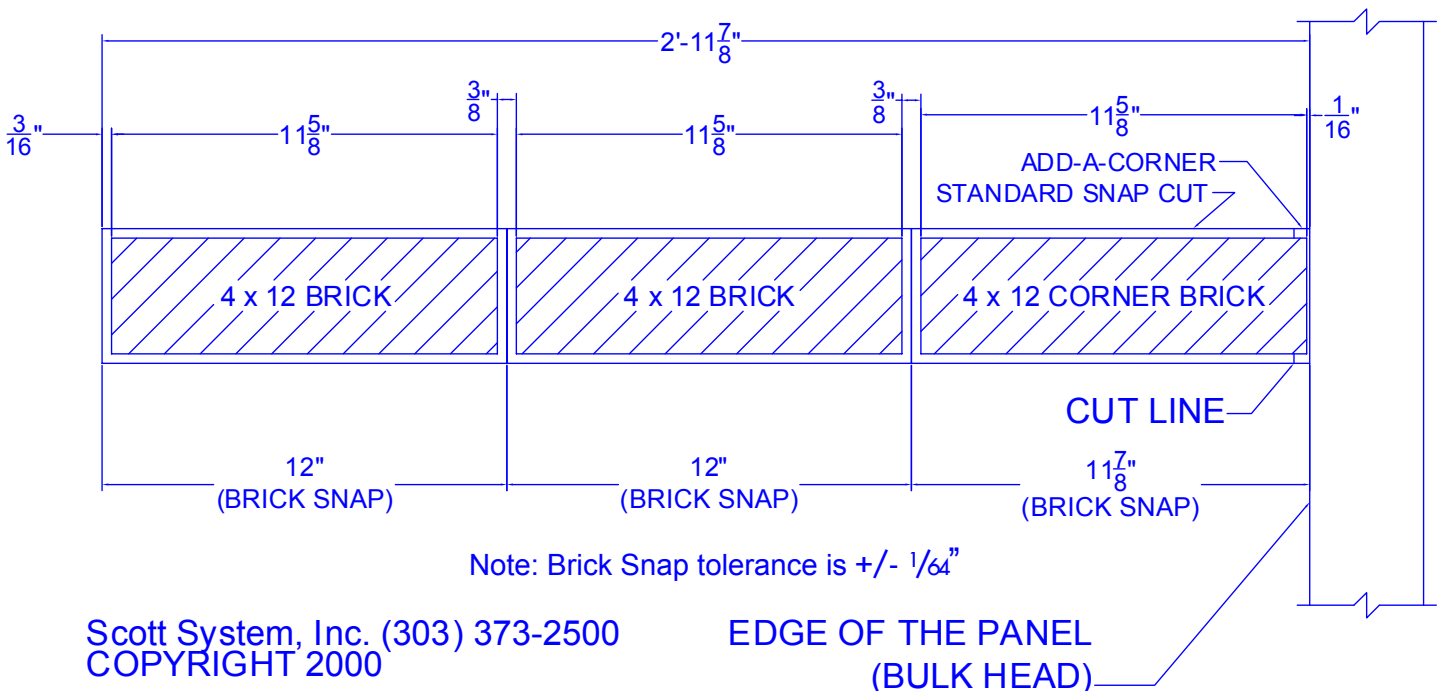

BRICK SNAP DIMENSIONAL LAYOUT

(1/2 MORTAR JOINT AT THE PANEL EDGE)

3 BRICKS, CENTER OF MORTAR JOINT TO CENTER OF MORTAR JOINT = 3'-0" (36") HORIZONTAL

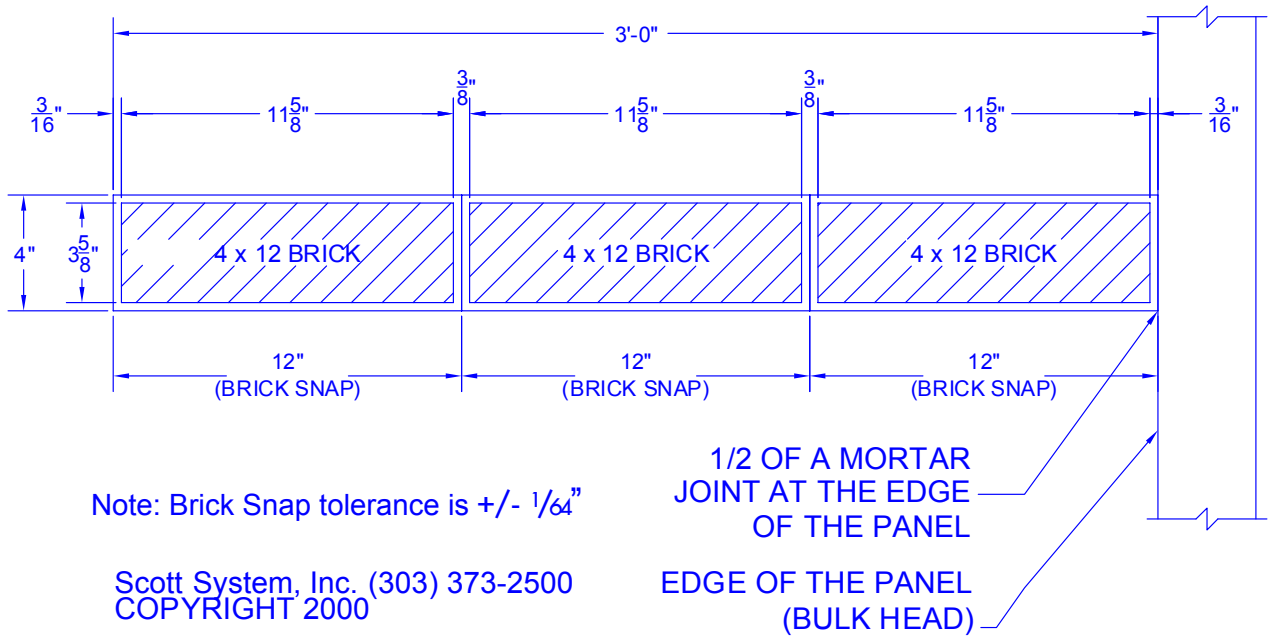

STANDARD BRICK SNAP DIMENSIONS

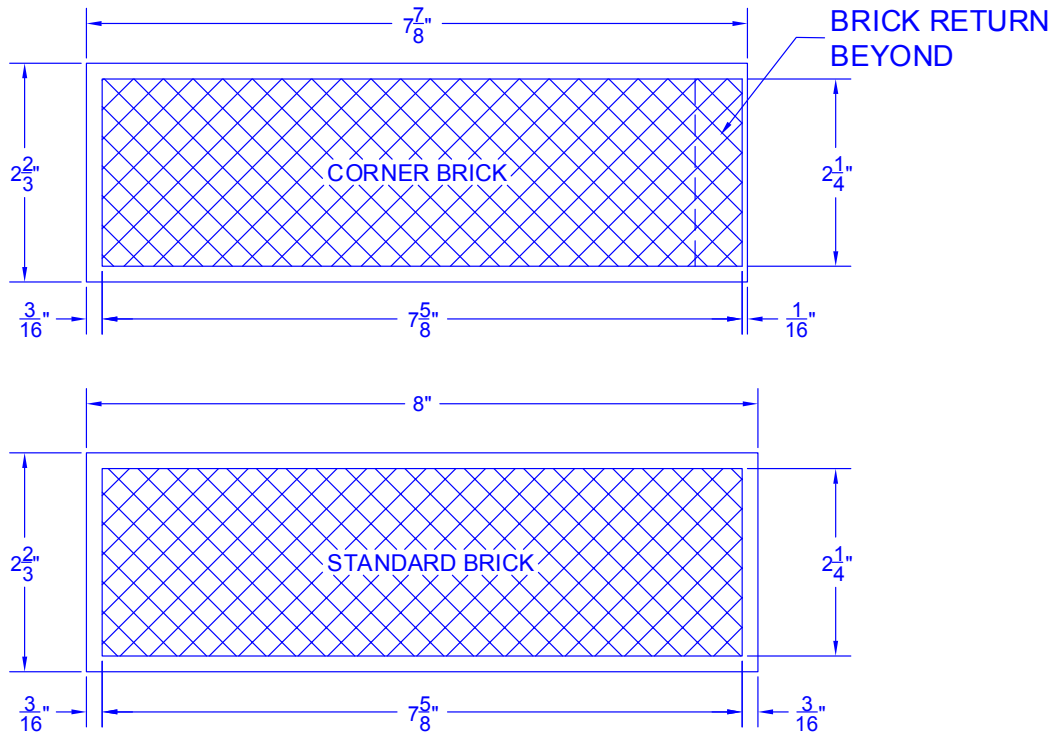

Scott System, Inc. (303) 373-2500
COPYRIGHT 2000

Note: Brick Snap tolerance is +/- 1/64"

Installation

A. Storage

We recommend protecting Brick Snap® from the elements. Brick Snap® should be stored on pallets out of direct sunlight.

B. Assembly in the Form

The bed or slab should be clean before placing the Brick Snap® in the form.

In the case of tilt-up construction and if your slab will be the finished floor surface, then a layer of bond breaker should be applied before Brick Snaps® are snapped into place. If a surface hardener is used on the slab, check the application with the manufacturer and explain the use of the Snap® system to them.

With Brick Snap®, the brick is already assembled in the plastic Snap® holder, so installation is a simplified process. Brick Snap® are snapped together with interlocking tabs. The Snaps® have two tabs on one side and four on the other, so you may have to “spin” the brick to line up the tabs. Make sure Snaps® are all locked together, otherwise the gap created by the tabs pushing against each other will create a place for leakage. Additionally, if the brick is removed from its Snap®, the Snap® carrier will lose some of its hold. In a horizontal application, this should not cause a problem. If there is any concern, replace the Snap®.

The Brick Snap® should be started in the center of the form, progress to the edge of the pattern and complete one row to make sure the layout works. This will allow you to adjust the edges uniformly if the brick overruns or comes up short of the frame work. If your panel layout is off, Brick Snap® make it possible to compact or stretch a 10 foot run by $\frac{1}{8}$ ”, a 20 foot run by $\frac{1}{4}$ ”, etc.



Brick snaps together at a rate of 50-60 sq. ft. per man hour.



Delivered Brick Snap® prepackaged with brick.

Brick Snap® can be placed in running bond or stacked bond patterns and the tabs will line up (a Flemish bond is also standard with the standard size brick).

If Brick Snap® are placed in extreme heat, direct sunlight and temperatures that exceed 90°F, the Snaps® may expand slightly, making it somewhat difficult to get the last Snaps® of the row into place. Usually, these can be “squeezed” in with some effort. Placing the last few pieces in the morning, before temperatures rise and the Snaps® expand, is often easiest.

If a brick is broken, it may be cut down and used as a half brick, otherwise, it should not be used.



The Brick Snap® may be walked on after being placed, but care should be taken not to kick up corners.

When snapping Brick Snap® together, a guide (chalk line, laser, etc.) can be used every two or three feet to ensure level coursing. It may be difficult to align an entire panel of brick, so using guide lines makes it easier to stay on course and ensures a panel-to-panel match of coursing runs.

The brick layout should be checked just prior to pouring concrete to make sure all bricks are flat. Shining a high-level intensity flashlight along the surface of the

brick at the same plane will show floaters before the pour.

When placing chairs (if used), care should be taken not to place them on the corners of the bricks. Pressure on the corners could cause the brick to become dislodged during the pour.

Glue (3M #3748) can be used to help hold the bricks in place in a vertical application, although, gluing typically is not necessary. Vertical or cast-in-place forms should use the Rim Snap® system to hold bricks in place.

A chamfer strip or rustication strip should be used as an edge detail when transitioning from brick coursing to a smooth band of concrete, or at the top or bottom of the coursing when the bricks do not abut the form edge. If a chamfer detail is undesirable, glue can be used to hold an accent band of Brick Snap® on the bed or slab.

C. Cutting the Brick and Snap®

If a Brick Snap® needs to be cut, a wet tile saw should be used. The brick should be cut while in the Snap®.

To complete a half-inch mortar joint on a cut brick, an End Cap is used. End Caps are purchased separately in quantities of 100.

Cutting an empty Snap® can be done by many different methods; however, the Sears Craftsman "Handi-Cut" hand-held cutters (approximately \$27) work well and have a replaceable blade. The Handi-Cut will also cut the standard size Brick Snap® in one stroke. A pair of chamfer/molding cutters will work as well.



D. Corner Application

The vertical half-inch brick on a corner return can be held on a wooden form with small staples (in the Snap[®]), hot glue (3M #3748), a rubber band or a cut Snap[®] as a clip to hold the brick in place.

On corners, the Brick Snap[®] or the full Snap[®] is cut (empty Snap[®]) at the small score line near the end of the Snap[®]. The corner brick is then placed in the Snap[®], and the Add-A-Corner is attached to the short leg of the corner brick. Please note that the Universal Corner Snaps[®] are used for 2"x8" size brick. When cutting the empty Snap[®], make sure to cut the correct end so that the tabs line up with the other corner Snaps[®]. Now the corner brick is ready to be placed in the form.



E. Pouring the Concrete

Generally no special measures are required in pouring the panel.

If the Brick Snap[®] are left in the sun all day and become hot to the touch, they should be "misted" with water prior to pouring concrete, or allowed to cool overnight. This reduces the possibility of the concrete flash setting before filling the joints.

If a chute is used in pouring, care should be taken not to let the concrete hit the brick from the side in a fashion that might knock it loose from its Snap[®].

Acceptable methods of vibration include stingers, grid vibrators, vibrating screeds and vibrating beds. The grid vibrator has been used successfully. Normal vibration should be used; however, external vibration or vibrating beds may cause loosening of bricks when the concrete wythe is two inches or less. Vibrating with a stinger is satisfactory, but avoid placing the tip straight on the brick in a vertical position.

When pouring thin panels of only two inches, it is not recommended to use vibrating screeds at a high level of vibration. If using self-compacting concrete, make sure to check the mock up for excessive leakage. Self-compacting concrete is an excellent alternative to traditional concrete and eliminates the need for vibration.





F. Finishing the Panel: Stripping the Snaps®

The Brick Snap® should be removed as soon as possible after the brick face is exposed to the sun and air. If removed right away, the Snaps® will be much easier to remove.

A one-inch putty knife or like tool can be used to loosen Snaps® in the same area to start the “peel.”

The Snaps® can be discarded or recycled by a plastic recycler.

The following section describes a way to remove the Snaps® and clean the panel in one step.

G. Finishing the Panel: Cleaning the Panel

High Pressure (2,500 - 3,000+ psi) hot water (190°F) will remove any concrete leakage and the protective wax coating on the face of the brick.

In many cases, Snaps® can be removed with a high pressure washer with an isolating head attachment. This eliminates one step in the process by removing the Snaps® and cleaning the panel simultaneously.

Areas of small concrete leakage around mortar joints can be removed with a putty knife; however, a certain amount of this may be desirable for aesthetic effect.



General

If you encounter any problems, or have any questions or comments, please contact us. We welcome your comments and/or any ideas you may have to improve on our product.

Brick Snap® is covered by one or more of these U.S. Patents 5667190, 5922235, or Des. 380139 and 16 foreign patents have been issued as of this printing.



Scott System, Inc.

10777 East 45th Ave. Denver, CO 80239
Phone: (303) 373-2500 Fax: (303) 373-2755
www.scottsystem.com